

Psychrometric Evaluation of Air Properties Under the Conditions of Plastic-Covered Greenhouses

Hesham A. Ahmed^{*}, Abdulkareem Al-Mogahed and Adel Mohammed Ahmed

Department of Agricultural Engineering and Modern Technologies, Faculty of Agriculture, Food and Environment, Sana'a University, Sana'a, Yemen

^{*}Corresponding author: haaag2010@su.edu.ye

ABSTRACT

Plastic-covered greenhouses are widely used in Yemen to cultivate various vegetable crops, often without adequate consideration of their microclimatic conditions. This study evaluated the key microclimatic factors affecting plant growth, including air temperature, relative humidity, humidity ratio, and heat content. Air temperature and relative humidity were measured both inside and outside a 36-meter-long plastic-covered greenhouse. Internal measurements were performed at three locations: the entrance, middle, and end sections. Psychrometric equations were used to calculate the humidity ratio and heat content of air. The results indicated that the air temperature inside the greenhouse was lower than outside during the early and late afternoon hours, with a maximum difference of 3.4°C. However, between 8:00 AM and 3:00 PM, the internal temperature exceeded the external temperature, peaking at 7.5°C higher at 11:00 AM. On average, the internal daytime temperature was 25.9°C (ranging from 8.3°C to 34.9°C), while the nighttime average was 11.8°C (ranging from 8.4°C to 19.1°C). The relative humidity inside the greenhouse remained consistently higher than outside, fluctuating between 32% and 84% throughout the day. The average internal daytime relative humidity was 49.7% (ranging from 32.0% to 86.4%), whereas the nighttime average was 76.1% (ranging from 52.3% to 86.3%). The humidity ratio and heat content remained stable at night, but increased significantly during the daytime. A longitudinal variation was observed, with the greenhouse entrance exhibiting a humidity ratio of 4.3 g of water per kg of air and a heat content of 12.2 kJ/kg, both lower than those recorded in the middle and end sections. The average internal daytime humidity ratio was 13.2 g of water per kg of air (ranging from 7.7 to 17.5), while the nighttime average was 8.3 g of water per kg of air (ranging from 7.6 to 9.5). Similarly, the average internal daytime heat content was 59.8 kJ/kg (ranging from 27.8 to 78.2), while the nighttime average was 33.4 kJ/kg (ranging from 27.9 to 43.3). Based on these findings, this study recommends enhancing greenhouse ventilation through mechanical systems powered by solar panels or by optimizing existing natural ventilation methods.

ARTICLE INFO

Keywords:

Temperature, Relative Humidity, Humidity Ratio, Saturated Water Vapor Pressure, Enthalpy

Article History:

Received: 8-March-2025,

Revised: 30-March-2025,

Accepted: 7-April-2025,

Available online: 30 April 2025.

1. INTRODUCTION

Protected agriculture aims to improve plant growth and productivity by creating a consistent and appropriate environment [1, 2]. Temperature, relative humidity, and solar radiation intensity are among the most important factors that must be controlled in greenhouses [3–6].

greenhouse temperature is typically maintained between 23 and 27 °C, while the relative humidity is between 70 and 80%. Most protected crops are grown best

in this range of temperatures and relative humidity levels [2]. Additionally, greenhouse temperature and relative humidity variations have an impact on plant disease infections [7, 8] as well as the regularity of plant growth and fruiting [9, 10].

Controlling the levels of environmental factors is only one aspect of the greenhouse environment, and the other aspect is the regular distribution of environmental factors. Furthermore, the values of environmental factors inside the greenhouse vary temporally, with varia-



tions in daylight hours, months, and seasons of the year, and spatially, depending on the dimensions and type of greenhouse cover [9, 11, 12].

Solar radiation transmitted through the greenhouse cover is the primary cause of temperature and relative humidity fluctuations as well as heat accumulation within the greenhouse [13, 14]. In addition to the effect of solar radiation, the greenhouse environment is described by a group of interconnected factors known as the psychrometric properties of air [15, 16].

The psychrometric properties of air are the study of the thermodynamic changes of air-vapor mixtures, emphasizing the relationship between temperature, actual water vapor pressure, and the heat and humidity ratio of air. Psychrometric studies of air involve the application of thermodynamic concepts to the analysis of conditions and processes involving moist air [17, 18].

Therefore, a comprehensive understanding of the psychrometric properties of humid air is important. It plays a key role in ventilation, cooling, and heating processes, and in understanding the thermal properties of insulation, covering, and building materials and their resistance to environmental conditions [19, 20]. Therefore, a good understanding of the main concepts and principles of psychrometric air characteristics, particularly for agricultural buildings, is important [17, 21].

Understanding psychrometric air characteristics in agricultural buildings and using psychrometric diagrams greatly helps in designing environmental control systems for farm buildings, such as ventilation, cooling, and heating systems [20, 21]. It also helps determine the priority of using any of these systems over others under certain environmental conditions. With these characteristics, designers can answer questions and make decisions while selecting an appropriate environmental control system for agricultural buildings [19, 22].

The psychrometric chart shows all the following properties: dry bulb temperature, wet bulb temperature, dew point temperature, relative humidity, total heat (enthalpy), humidity ratio, and specific volume of moist air [17, 22, 23].

Temperature, relative humidity, and other psychrometric properties of air are directly affected by variations in the intensity of solar radiation [24, 25]. Based on the heat and mass balance, greenhouses have two types of heat buildup: sensible heat and latent heat [26]. Sensible heat is closely correlated with greenhouse air temperature, whereas latent heat is directly proportional to the greenhouse air humidity ratio [27]. In greenhouses, the thermal content of air or enthalpy refers to the total amount of heat energy in the air, which includes both the temperature and the humidity ratio of the air. This concept is important because it helps to understand the energy balance in a greenhouse environment, which affects plant growth, energy use for heating or cooling, and overall climate control [28].

Temperature and relative humidity cause changes in all psychrometric properties of greenhouse air, including the heat and humidity ratios [19, 22]. However, the physiological processes of all plants are affected by the psychrometric properties of air change. For example, low temperatures and high relative humidity increase the potential of plant stomatal closure, reducing photosynthetic efficiency and plant intake of water and nutrients [29, 30]. This also increases the risk of plant pathogen spread [31]. Conversely, high temperature and low relative humidity may result in heat stress in plants [29, 30].

There are two main ways in which the characteristics of air are determined by psychrometrics. The first involves the use of psychrometric charts. Psychrometric charts are employed to identify the instantaneous psychrometric properties of air by knowing the two properties of humid air, such as the temperature of dry air and relative humidity. This method is known as the steady psychrometric property of the moist air. The second method involves the use of empirical psychrometric equations to determine the temporal change in psychrometric properties of humid air during a specific period [22].

The psychrometric properties of air are crucial for providing valuable insights that will help in regulating the environment of protected cultivation systems. A comprehensive understanding of these properties, along with the thermal behavior of such systems, is essential for the efficient design of ventilation, heating, and cooling systems. This study aimed to assess the psychrometric properties of air within plastic-covered greenhouses to enhance ventilation systems for protected agriculture in Sana'a City. Specifically, the research will examine the temporal and longitudinal variations in air properties, including air temperature, relative humidity, humidity ratio, and heat content, were investigated. Furthermore, this study sought to evaluate the suitability of these greenhouses for cultivating protected crops in Sana'a, Yemen, by assessing their ability to maintain optimal temperature and relative humidity levels.

2. MATERIALS AND METHODS

2.1. EXPERIMENTAL SITE

The experiment was conducted in a greenhouse with a curved roof covered with a 200-micron-thick polyethylene sheet. For ventilation, the greenhouse's plastic cover was overlapped with three white shade nets, each with a permeability of 20% and width of 2.0 meters. The greenhouse used in the experiment was 36.0 meters in length and 9.0 meters in width, with a total floor area of 324 m². The sidewalls were 2.0 meters high, and the circular arc of the roof had a height of 1.5 meters (Figure 1). The greenhouse is oriented in a north-south direction and is located at the educational farm of the College of Agriculture, Food, and Environment, Sana'a University

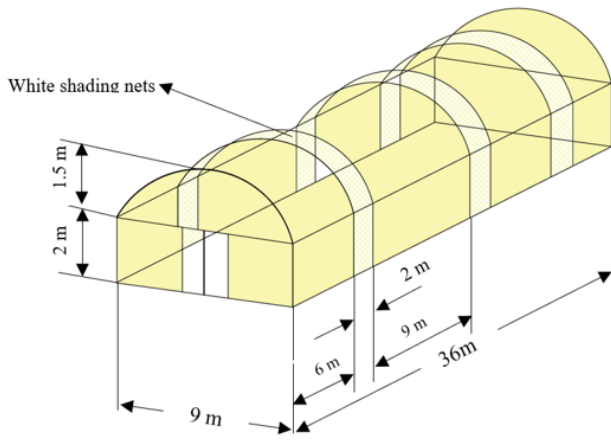

Figure 1. Schematic diagram of the experimental greenhouse, showing ventilation openings along the structure, covered with white shading nets

(Sana'a City, Republic of Yemen, 44°10' N, 55°21' E) at an elevation of 3200 m above sea level. Cucumber plants were cultivated using a soil-based growing system. Mulch was applied to the plant rows to conserve moisture and suppress weed growth. A drip irrigation system provided controlled and efficient water supply directly to the root zone. Irrigation was scheduled daily for an average of 20 min to maintain optimal soil moisture levels.

2.2. EXPERIMENTAL SETUP AND MEASUREMENTS

The temperature and relative humidity were measured at three points along the length of the greenhouse and at a height of 1 m from the greenhouse floor (Figure 2). Outdoor temperature and relative humidity were measured at a height of 6 m from the greenhouse floor. Data loggers (RC-51H, Technology, Inc., USA) with a recording capacity of 32,000 readings, a temperature measurement error of $\pm 0.5^\circ\text{C}$, and a relative humidity measurement error of $\pm 3\%$ were used to measure the temperature and relative humidity both inside and outside the greenhouse. The data loggers were programmed to record the temperature and relative humidity every five minutes for 30 days, from May 1, 2024, to June 1, 2024. Prior to the experiment, the temperature and relative humidity data loggers were covered with aluminum foil to protect them from direct sunlight.

2.3. CALCULATION OF PSYCHROMETRIC PROPERTIES OF AIR

2.3.1. The humidity ratio

The humidity ratio of air is also known as specific humidity. It is defined as the mass of water vapor molecules per unit of air molecules within a limited air volume. The humidity ratio of air was calculated using the equation

reported by ASHRAE [22] as follows:

$$HR = 0.621945 \times \frac{P_w}{P - P_w} \quad (1)$$

Where HR is the humidity ratio of air ($\text{kg}_{\text{water}}/\text{kg}_{\text{air}}$), P_w is the partial water vapor pressure (kPa), and P is the atmospheric pressure in the study area (kPa). The partial water vapor pressure is the pressure exerted by water vapor as a component of the total gas mixture in the atmosphere. The partial water vapor pressure represents the fraction of the total atmospheric pressure that is specifically due to the presence of water vapor, assuming that the gas behaves ideally [32]. The partial water vapor pressure was calculated using the equation reported by ASHRAE [22], as follows:

$$P_w = \frac{RH}{100} \times P_{s,wv} \quad (2)$$

Where RH is the relative humidity of the air and is the saturated water vapor pressure. The atmospheric pressure in the study area (P in kPa) was assumed to consist of dry air, which behaves as a perfect gas. The atmospheric pressure in the study area was calculated using the equation reported by ASHRAE [22]:

$$P = 101.325 \times \left(1 - 2.25577 \times 10^{-5} Z\right)^{5.2559} \quad (3)$$

Where Z is the altitude (m). The saturated water vapor pressure ($P_{s,wv}$ in kPa) is the highest partial pressure of water vapor that can exist at a specific temperature before air becomes saturated and condensation occurs. The saturated water vapor pressure was calculated using the Tetten formula reported by Monteith and Unsworth [20], as follows:

$$P_{s,wv} = 0.611 \times e^{\left(\frac{17.27 T_{db}}{T_{db} + 237.3}\right)} \quad (4)$$

Where T_{db} is the dry bulb temperature ($^\circ\text{C}$).

2.3.2. The heat content

In thermodynamics, the heat content or enthalpy (h , kJ/kg) is an expression of the total heat energy in a system that can be used to perform work or transferred as heat [33]. In greenhouses, the thermal content of air (h in kJ/kg) refers to the total amount of heat energy in the air, which includes both the temperature and humidity ratio of the air [28, 34]. The heat content of air (enthalpy) can be expressed using the ideal gas law [22] as follows:

$$h = 1.006 T_{db} + HR (2501 + 1.805 T_{db}) \quad (5)$$

where 1.006 is the specific heat of dry air at constant pressure (kJ/kg. $^\circ\text{C}$), 2501 is the latent heat of vaporization at 0°C (kJ/kg), and 1.805 is the specific heat of water vapor at constant pressure (kJ/kg. $^\circ\text{C}$).

The data collected throughout the 30-day experimental period were averaged to represent the temperature

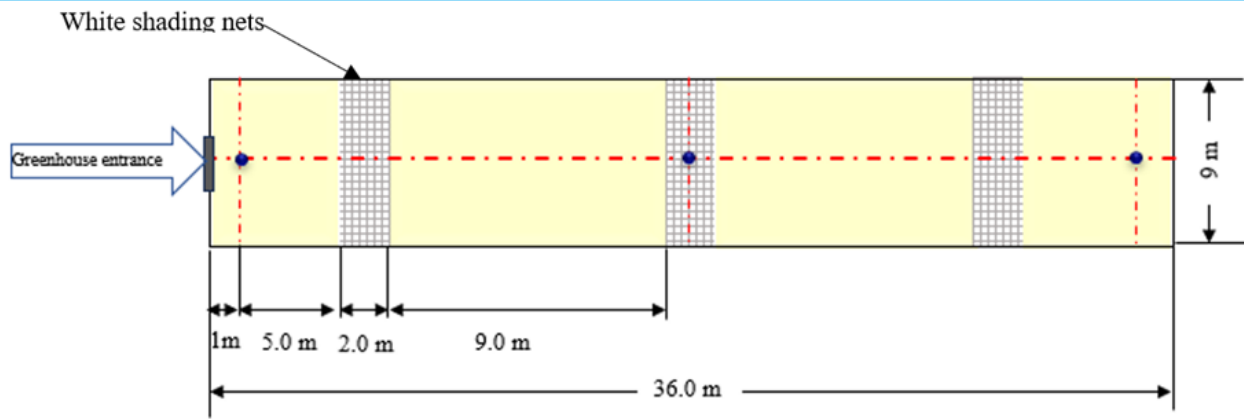

Figure 2. Schematic vertical view of the experimental greenhouse, showing temperature and relative humidity measurement locations. Blue circles indicate these measurement points.

and relative humidity readings every five minutes for 24 h (from 00:00:00 to 23:55:00). The psychrometric properties of air were calculated using the mean values of temperature and relative humidity.

3. RESULTS

3.1. AIR TEMPERATURE

Figure 3 illustrates the diurnal variation in the air temperature inside and outside the plastic-covered greenhouse. The results show that between 12:00 AM and 7:00 AM, the air temperature inside the greenhouse was lower than outside, with a maximum recorded difference of 3.4°C. Additionally, no significant variation in the air temperature distribution was observed along the length of the greenhouse during this period.

From 8:00 to 3:00, the average air temperature inside the plastic-covered greenhouse consistently exceeded that of the external environment. The maximum temperature difference of 7.5°C was recorded at 11:00 AM. A temperature variation along the greenhouse's length was also observed, with the largest longitudinal difference of 8.5°C occurring between the entrance and middle sections at 11:00 AM. However, no significant temperature difference was detected between the middle and the end sections.

Between 3:30 PM and 12:00 AM, the average air temperature inside the plastic-covered greenhouse was 2.4°C lower than the external temperature, with a maximum difference of 3.2°C. However, no significant longitudinal temperature variations were observed in the entrance, middle, or end sections of the greenhouse.

Comparing the air temperature inside the plastic-covered greenhouse to the optimal temperature for plant growth (approximately 25°C), the results indicated that temperatures during the early morning (00:00–08:30) and nighttime hours (18:00–00:00) were lower than optimal. This suggests a need for enhanced thermal insula-

tion during these periods.

The temperatures between 08:30–10:00 and 15:00–18:00 were within the optimal range for plant growth. However, from 10:00 to 15:00, the air temperatures exceeded the optimal range, highlighting the need for improved ventilation. This can be achieved by enhancing natural ventilation systems or by incorporating mechanical ventilation powered by solar panels.

Table 1 summarizes the mean, standard deviation, and the highest and lowest temperatures recorded inside and outside the plastic-covered greenhouse during the experimental period. The results indicated a clear temperature variation inside the greenhouse between day and night.

During the daytime, the outside temperature ranged from a minimum of 11.5°C to a maximum of 30.5°C. The average air temperature inside the greenhouse was generally higher. At the entrance, the average temperature was 24.8°C, with a maximum of 33.3°C and a minimum of 8.5°C. The middle section exhibited an even higher average temperature of 26.4°C, reaching a maximum of 35.8°C and a minimum of 8.0°C. At the end, temperatures were slightly higher than in the middle, with an average of 26.7°C, a maximum of 36.2°C, and a minimum of 8.5°C.

At night, the temperature variation followed an inverse pattern, with indoor temperatures being lower than those outside the plastic-covered greenhouse. The average outdoor temperature was 15.0°C, ranging from a minimum of 11.7°C to a maximum of 21.2°C.

In contrast, the temperature inside the greenhouse is lower. At the entrance, the average temperature was 11.9°C, while the middle section recorded a slightly lower average of 11.4°C, with a minimum of 8.0°C. Similarly, the end section exhibited temperatures close to the other interior areas, with an average of 12.0°C, a maximum of 19.2°C, and a minimum of 8.7°C.

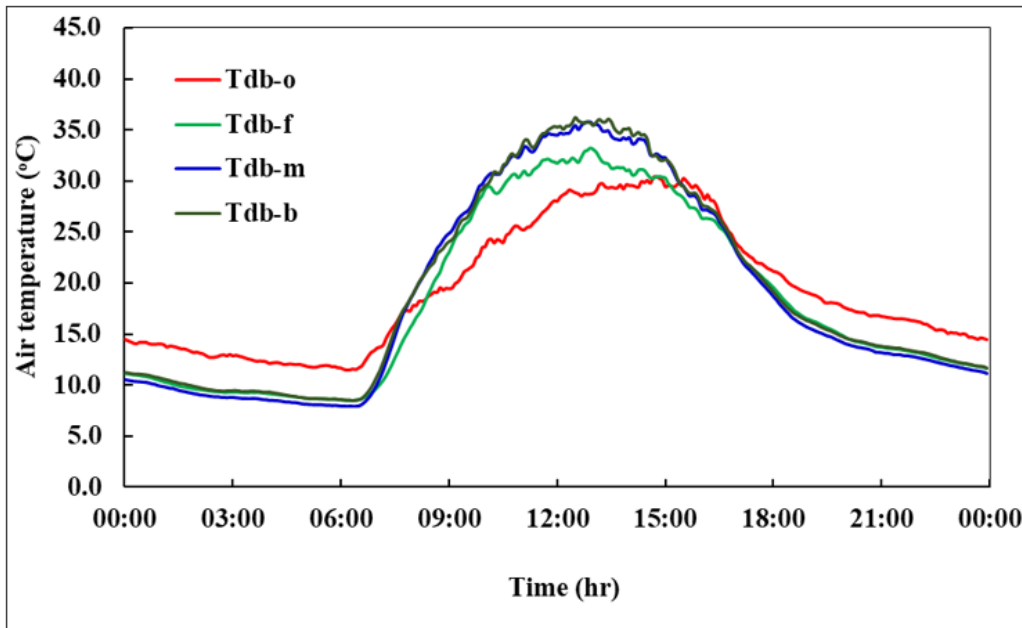

Figure 3. Diurnal variation in air temperature inside a plastic-covered greenhouse. Tdb-o represents the outside air temperature, while Tdb-f, Tdb-m, and Tdb-b indicate the air temperature in the entrance, middle, and end sections of the greenhouse, respectively.

Table 1. Mean, standard deviation, maximum, and minimum temperatures (°C) inside and outside the plastic-covered greenhouse during day and night

Daily period	Measurement position	Average	Standard deviation	Max	Min
Daytime	Outside the greenhouse	23.8	5.7	30.5	11.5
	Greenhouse entrance	24.8	7.6	33.3	8.5
	Middle of greenhouse	26.4	8.3	35.8	8.0
	End of the greenhouse	26.7	8.3	36.2	8.5
Night time	Outside the greenhouse	15.0	2.5	21.2	11.7
	Greenhouse entrance	11.9	2.8	19.6	8.6
	Middle of greenhouse	11.4	2.8	18.7	8.0
	End of the greenhouse	12.0	2.7	19.2	8.7

3.2. AIR RELATIVE HUMIDITY

Figure 4 illustrates the daily variation in the relative humidity within and outside the plastic-covered greenhouse. The results indicated that the relative humidity within the plastic-covered greenhouse was higher than that outside the greenhouse.

The study results also showed a consistent relative humidity from 12:00 AM to 7:00 AM, with an average of approximately 82%. During this time, there was no significant difference in the longitudinal distribution of the relative humidity between the entrance, middle, and end sections of the plastic-covered greenhouse.

From 7:30 AM to 1:30 PM, the average relative humidity inside the plastic-covered greenhouse decreased from 84 to 32%. However, no longitudinal relative humidity variation was observed among the entrance, middle, and end sections of the plastic-covered greenhouse.

Between 2:00 PM and 12:00 PM, the average rela-

tive humidity inside the plastic-covered greenhouse increased from 33 to 78% and no longitudinal relative humidity variation was observed between the middle and end sections of the plastic-covered greenhouse. The relative humidity in the entrance area of the plastic-covered greenhouse was 10% lower than that in the middle and end sections.

Comparing the relative humidity inside the plastic-covered greenhouse to the optimal level for plant growth (approximately 50%), the results indicated that the relative humidity during the periods from 00:00 to 10:00 and 18:00 to 00:00 was within the optimal range for plant growth.

However, the relative humidity between 10:00 and 18:00 was lower than the optimal range, indicating the need for air humidification potentially through small evaporative cooling units. However, this approach is often impractical for many farmers using greenhouse systems, because of the energy requirements required to operate

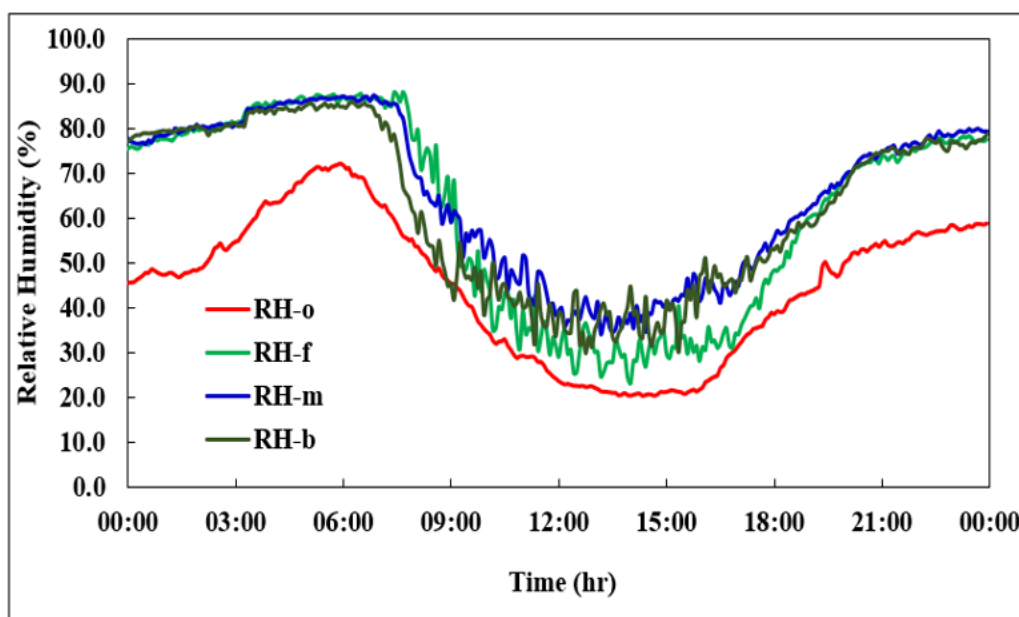

Figure 4. Diurnal variation in air relative humidity inside a plastic-covered greenhouse. RH-o represents the outside relative humidity, while RH-f, RH-m, and RH-b indicate the air relative humidity in the entrance, middle, and end sections of the greenhouse, respectively.

evaporative cooling units.

The relative humidity values recorded inside and outside the plastic-covered greenhouse during both the daytime and nighttime are summarized in **Table 2**. The results indicated significant variations in relative humidity depending on the measurement position and time of day.

The outside relative humidity during the daytime ranged from a minimum of 20.3% to a maximum of 71.8%, with an average of 35.4%. In contrast, the relative humidity inside the plastic-covered greenhouse was consistently higher at all measurement points. At the greenhouse entrance, the average relative humidity was 47.0%, with a maximum of 88.1% and minimum of 23.2%. The middle section of the plastic-covered greenhouse exhibited a higher average relative humidity of 53.1%, reaching a maximum of 87.3% and minimum of 34.4%. At the end of the plastic-covered greenhouse, the relative humidity was slightly lower than that in the middle, with an average of 48.9%, maximum of 85.8%, and minimum of 29.9%.

The findings of this study indicate that the variation between the minimum and maximum relative humidity levels recorded across the three greenhouse locations exceeded 50%, demonstrating significant temporal fluctuations in the relative humidity distribution within plastic-covered greenhouses.

3.3. HUMIDITY RATIO

Figure 5 illustrates the diurnal variation in the air humidity ratio inside and outside of the plastic-covered greenhouse. The results indicated that the humidity ratio of the air within the plastic-covered greenhouse was higher

than that outside the greenhouse.

Between 12:00 and 7:00, the air humidity content remained stable at an average of $7.9 \text{ g}_{\text{water}}/\text{kg}_{\text{air}}$. Throughout this period, no notable fluctuations in humidity ratio were observed along the entire length of the plastic-covered greenhouse.

Between 7:00 and 9:00, a slight variation in the air humidity ratio was observed along the entire length of the plastic-covered greenhouse. During this period, the humidity ratio ranged from 8.6 to $16.1 \text{ g}_{\text{water}}/\text{kg}_{\text{air}}$, with an average value of $11.7 \text{ g}_{\text{water}}/\text{kg}_{\text{air}}$.

Between 9:00 AM and 7:00 PM, a significant longitudinal variation in the air humidity ratio was observed. The average humidity ratio in the entrance section of the plastic-covered greenhouse was $4.3 \text{ g}_{\text{water}}/\text{kg}_{\text{air}}$ lower than that in the middle section. However, no significant longitudinal variation in humidity ratio was observed between the middle and end sections.

Between 7:00 PM and 12:00 AM, the average air humidity ratio in the plastic-covered greenhouse was $4.3 \text{ g}_{\text{water}}/\text{kg}_{\text{air}}$. However, no significant longitudinal variation in humidity ratio was observed between the entrance, middle, and end sections of the greenhouse.

Table 3 summarizes the mean and standard deviation values, as well as the highest and lowest air humidity ratios recorded inside and outside the plastic-covered greenhouse. During the daytime, the humidity ratio was significantly higher inside the greenhouse compared to outside, with the middle of the greenhouse recording the highest mean value ($14.7 \text{ g water/kg air}$). The end of the greenhouse also showed a high humidity ratio ($13.7 \text{ g water/kg air}$), suggesting the accumulation of humid air

Table 2. Mean, standard deviation, maximum, and minimum relative humidity (%) inside and outside the plastic-covered greenhouse during day and night

Daily period	Measurement position	Average	Standard deviation	Max	Min
Daytime	Outside the greenhouse	35.4	15.5	71.8	20.3
	Greenhouse entrance	47.0	21.2	88.1	23.2
	Middle of greenhouse	53.1	16.3	87.3	34.4
	End of the greenhouse	48.9	15.3	85.8	29.9
Night time	Outside the greenhouse	54.4	8.3	72.1	38.6
	Greenhouse entrance	75.7	9.2	87.4	48.2
	Middle of greenhouse	76.9	7.7	86.9	55.7
	End of the greenhouse	75.7	8.4	85.5	52.6

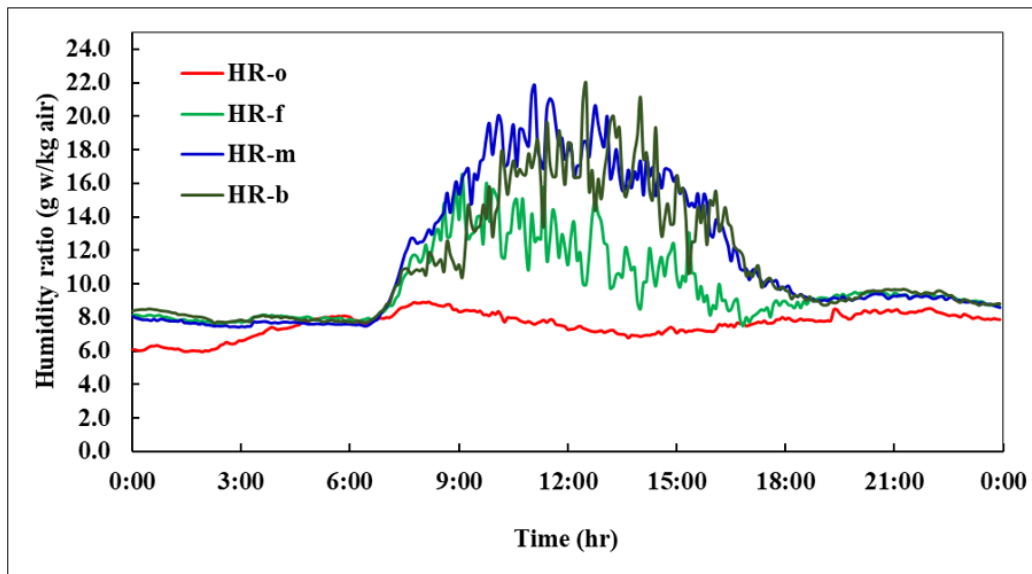

Figure 5. Diurnal variation in air temperature inside a plastic-covered greenhouse. Tdb-o represents the outside air temperature, while Tdb-f, Tdb-m, and Tdb-b indicate the air temperature in the entrance, middle, and end sections of the greenhouse, respectively.

towards the rear section.

At night, the humidity ratio differences between locations within the greenhouse were much smaller. The external humidity ratio remained relatively stable (7.5 g water/kg air), while the internal locations exhibited less variability. The highest recorded night-time humidity ratio was at the greenhouse entrance and end (8.6 g water/kg air), whereas the lowest was in the middle (8.4 g water/kg air). This suggests a more uniform humidity distribution at night.

3.4. HEAT CONTENT (ENTHALPY)

Figure 6 illustrates the daily variation in the heat content of the air within and outside the plastic-covered greenhouse. The results indicate that the heat content of the air within the plastic-covered greenhouse was higher than that outside the greenhouse.

Between 12:00 and 6:30 AM, the heat content of the air inside the plastic-covered greenhouse remained relatively stable at an averaging 29.2 kJ/kg. During this

period, a gradual decline in heat content was observed, decreasing from 31.8 kJ/kg to 27.8 kJ/kg. Notably, no significant variation in heat content was detected along the entire length of the greenhouse.

Between 7:00 AM and 9:00 AM, the heat content of the air inside the plastic-covered greenhouse increased from 32.3 kJ/kg to 52.7 kJ/kg. Additionally, a slight variation in heat content was observed along the entire length of the greenhouse.

Between 9:00 AM and 7:00 PM, a substantial longitudinal variation in air heat content was observed inside the plastic-covered greenhouse. On average, the heat content in the entrance section is 12.2 kJ/kg lower than that in the middle section. However, no significant variation was detected between the middle and end sections where the heat content ranged from 38.6 to 88.1 kJ/kg.

Between 7:00 PM and 12:00 AM, the average heat content of the air inside the plastic-covered greenhouse was 36.8 kJ/kg, gradually decreasing from 39.0 kJ/kg to 33.6 kJ/kg over time. However, no significant longitudinal

**Table 3.** Mean, standard deviation, maximum, and minimum humidity ratio of air ($g_{\text{water}}/kg_{\text{air}}$) inside and outside the plastic-covered greenhouse during day and night

Daily period	Measurement position	Average	Standard deviation	Max	Min
Daytime	Outside the greenhouse	7.8	0.6	9.0	6.8
	Greenhouse entrance	11.1	2.3	16.6	7.5
	Middle of greenhouse	14.7	3.7	21.8	7.5
	End of the greenhouse	13.7	3.4	21.9	7.7
Night time	Outside the greenhouse	7.5	0.9	8.6	6.0
	Greenhouse entrance	8.6	0.7	9.5	7.6
	Middle of greenhouse	8.4	0.8	9.9	7.4
	End of the greenhouse	8.6	0.7	9.7	7.7

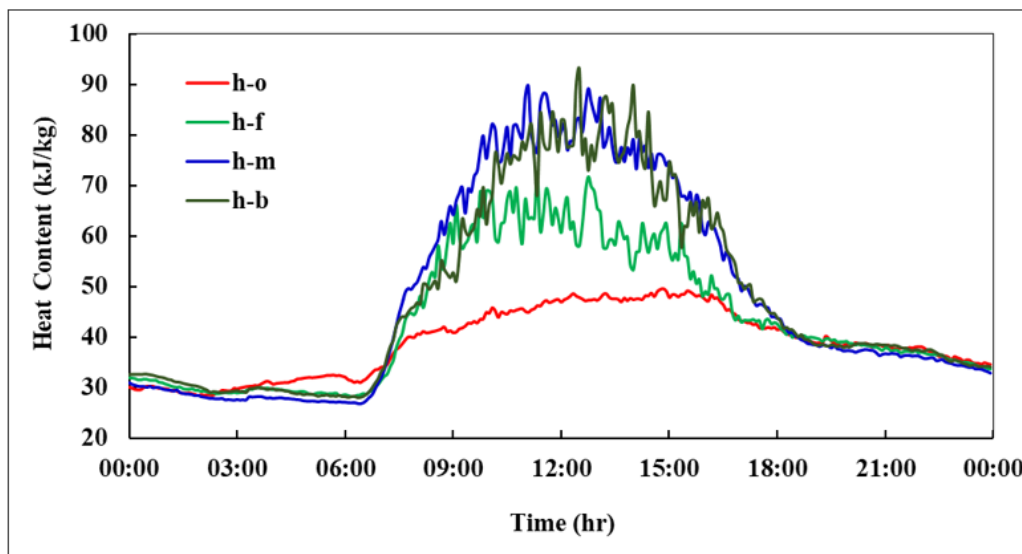
**Figure 6.** Diurnal variation in air heat content inside a plastic-covered greenhouse. h-o represents the outside heat content, while h-f, h-m, and h-b indicate the air heat content in the entrance, middle, and end sections of the greenhouse, respectively

variations in the heat content were observed across the entrance, middle, and end sections of the greenhouse.

Table 4 summarizes the mean, standard deviation, and the highest and lowest recorded air heat contents, both inside and outside the plastic-covered greenhouse, throughout the experimental period. During the daytime, the heat content was significantly higher inside the greenhouse than outside the greenhouse. The mean heat content outside the greenhouse was 43.8 kJ/kg, with a maximum of 49.6 kJ/kg and a minimum of 31.0 kJ/kg. The heat content increased substantially inside the plastic-covered greenhouse. The heat content at the greenhouse entrance averaged 53.3 kJ/kg, with a significant variation, ranging from 28.2 kJ/kg to 71.8 kJ/kg. The middle of the greenhouse exhibited the highest heat content, with a mean of 64.3 kJ/kg, a maximum of 89.6 kJ/kg, and a minimum of 26.9 kJ/kg, indicating large fluctuations. Similarly, the end of the greenhouse had high heat content levels, with a mean of 61.9 kJ/kg and a peak of 92.9 kJ/kg. These results suggest that the middle and

end sections of the greenhouse accumulate more heat, likely owing to reduced air circulation in these areas.

At night, the heat content inside and outside of the greenhouse became more uniform. The mean heat content outside the greenhouse dropped to 34.1 kJ/kg, with a maximum of 41.6 kJ/kg and a minimum of 28.4 kJ/kg. Inside the greenhouse, heat content ranged between 32.7 kJ/kg and 33.9 kJ/kg across different positions, indicating significantly lower variation compared to daytime.

The middle of the greenhouse recorded the lowest mean heat content at night (32.7 kJ/kg), while the end had a slightly higher value of 33.9 kJ/kg. The smaller differences between the positions at night suggest a more stable thermal environment, likely due to the dissipation of accumulated heat from the day.

4. DISCUSSION

Table 4. Mean, standard deviation, maximum, and minimum heat content of air (kJ/kg) inside and outside the plastic-covered greenhouse during day and night

Daily period	Measurement position	Average	Standard deviation	Max	Min
Daytime	Outside the greenhouse	43.8	4.9	49.6	31.0
	Greenhouse entrance	53.3	11.7	71.8	28.2
	Middle of greenhouse	64.3	17.5	89.6	26.9
	End of the greenhouse	61.9	16.8	92.9	28.1
Night time	Outside the greenhouse	34.1	4.1	41.6	28.4
	Greenhouse entrance	33.7	4.3	42.5	28.4
	Middle of greenhouse	32.7	4.6	43.7	27.2
	End of the greenhouse	33.9	4.3	43.8	28.2

4.1. AIR TEMPERATURE IN THE PLASTIC-COVERED GREENHOUSE

Temperature is a crucial factor in greenhouses because it directly affects plant growth, development, and productivity [35, 36]. Optimal temperatures promote efficient photosynthesis, enabling plants to produce energy and grow [37, 38]. The results indicated that during the night and late afternoon hours, the air temperature inside the plastic-covered greenhouse was lower than the outside temperature (Figure 3 and Table 1). This suggests that plastic-covered greenhouses may lead to a drop in nighttime temperatures, causing the internal environment to be cooler than the surrounding external conditions. This result can be attributed to radiative cooling. Radiant cooling is commonly observed in greenhouses covered with thin plastic films, particularly during cold, calm, and cloudless nights, when there is no heating system in operation. Under these conditions, it has been found that the temperature inside the greenhouse can drop below the outside temperature [14, 39, 40]. Furthermore, at night, both the ground and plants inside the greenhouse release heat through radiation. Plastic, which is a poor emitter of infrared radiation, traps this heat within the greenhouse. However, it also does not sufficiently reflect the heat inside, allowing it to escape through the plastic cover. In contrast, the outside environment loses heat directly to the sky, which is often cooler than the interior of the greenhouse [41]. This result aligns with the findings of Kim et al. [14], who reported that the nighttime air temperature within a plastic-covered greenhouse was lower than the external air temperature.

The study revealed that from 08:00 to 15:00, the greenhouse temperature remained consistently higher than the external environment, reaching a maximum difference of 7.5°C at 11:00 (Figure 3). The temperature difference between the entrance and middle sections peaked at 8.5°C, whereas no significant longitudinal variation was observed between the middle and end sections (Figure 3, Table 1). This result can be attributed to several factors, including the influence of external environmental conditions on the greenhouse microcli-

mate [42, 43], the quality of the greenhouse cover [14, 44], the structural design of the greenhouse [42, 45–47], and the greenhouse effect [6, 46]. These effects occur because the plastic cover permits solar radiation to enter the greenhouse, warming the air, soil, and plants. However, greenhouses trap infrared radiation emitted by heated surfaces, restricting its escape and thereby elevating the internal temperature above the external environment [26, 27, 48]. This temperature difference is likely due to the increased absorption of solar energy within the plastic-covered greenhouse [9] and the reduced heat loss resulting from the insulating properties of the plastic cover [13].

The maximum temperature difference and longitudinal temperature variation observed at 11:00 (Figure 3) can be attributed to the peak in solar radiation intensity around midday [9, 49]. The maximum longitudinal temperature difference of 8.5°C between the entrance and middle sections at 11:00 AM (Figure 3) indicates non-uniform heat distribution within the greenhouse [9, 11], likely due to variations in ventilation or air circulation [50, 51]. This can explain the lack of variation in the longitudinal temperature distribution between the middle and rear sections of a plastic-covered greenhouse [52]. The results obtained were consistent with those of Kim et al. [14], who found that the air temperature in a plastic-covered greenhouse was higher than the outside temperature, with a maximum difference of 20°C observed at noon. The study also compared temperature levels in greenhouses covered with plastic, polycarbonate, and glass and found that the highest temperatures were recorded in the plastic-covered greenhouse. Similarly, Ahmed et al. [9] reported that the longitudinal variation in air temperature between the entrance and end sections of a greenhouse increases with the intensity of solar radiation.

4.2. AIR RELATIVE HUMIDITY IN THE PLASTIC-COVERED GREENHOUSE

Relative humidity is crucial in greenhouses because it directly affects plant growth, transpiration, disease preva-

lence, and overall plant health [53]. Proper relative humidity levels help maintain optimal stomatal function, ensuring efficient CO₂ exchange for photosynthesis [29]. High relative humidity can lead to condensation on greenhouse surfaces, promoting mold growth and the spread of disease [54, 55]. The results of this study, presented in Figure 4 and Table 2, indicate that the relative humidity inside the plastic-covered greenhouse consistently exceeded that of outdoor air throughout the day. Furthermore, no changes were observed in either the relative humidity or the longitudinal distribution of the relative humidity during the night. In contrast, during the day, significant variations were observed in both the relative humidity values and their longitudinal distribution, characterized by a sharp decrease until midday, followed by a gradual increase toward sunset.

In this context, it can be concluded that relative humidity levels within greenhouses are influenced by multiple factors, with the most prominent being internal temperature, ventilation, plant and soil evapotranspiration, irrigation practices, solar radiation, greenhouse covering materials, and external weather conditions [42, 56].

The reduced relative humidity of the external air is a result of Yemen's classification of a semi-arid region [57]. The increased relative humidity inside the greenhouse is primarily attributed to reduced air exchange with the external environment, coupled with moisture contributions from plant transpiration [51].

The higher nighttime relative humidity can be attributed to the lower temperatures and reduced ventilation, leading to decreased evaporation rates and increased moisture retention. This effect is particularly pronounced inside greenhouses, where moisture accumulates due to plant transpiration. Similar trends have been reported in previous studies, where greenhouses had moderate diurnal humidity fluctuations and created a more stable microclimate for plant growth [14, 28].

The significant decline in relative humidity until midday, followed by a gradual increase toward sunset (Figure 4), was attributed to the interaction of external and internal factors influencing the greenhouse microclimate. In naturally ventilated, plastic-covered greenhouses, the relative humidity typically decreases between 7 AM and 2 PM owing to increasing solar radiation and the associated rise in temperature. After 2 PM, both the temperature and solar radiation declined, resulting in a gradual increase in relative humidity. Reduced ventilation in the evening further contributes to this increase until sunset [9, 14, 58]. Conversely, higher relative humidity in the center of the greenhouse indicates more stable humidity levels in areas farther from ventilation openings, where air circulation is limited [49, 58].

4.3. AIR HUMIDITY RATIO IN THE PLASTIC-COVERED GREENHOUSE

The humidity ratio plays a crucial role in transpiration and directly affects the water and nutrient uptake in plants [59]. Maintaining optimal humidity levels helps prevent condensation on leaves and surfaces, thereby reducing the risk of disease [60, 61]. Certain crops, such as tomatoes, depend on precise humidity conditions for pollen viability and effective pollination [62]. By monitoring the humidity ratio, growers can optimize ventilation, heating, and cooling, leading to a more efficient energy use [55, 61]. Additionally, proper humidity control minimizes water loss and wilting, preserving crop freshness and overall plant health [63, 64].

Throughout the day, the humidity ratio within the plastic-covered greenhouse remained consistently higher than that in the external environment (Figure 5 and Table 3). This observation aligns with expectations because the greenhouse structure inherently retains heat and moisture, resulting in a more humid microclimate. These findings are consistent with previous studies indicating that greenhouses generally exhibit elevated humidity levels compared to external conditions owing to plant transpiration and limited ventilation [65, 66].

During the nighttime hours, the air humidity ratio remained stable, with no significant variations observed along the length of the greenhouse (Figure 5). The stability of the humidity ratio within plastic-covered greenhouses is largely influenced by the minimal temperature variation between internal and external environments. This is primarily because of the absence of direct solar radiation, which typically causes significant temperature fluctuations [43]. Additionally, the reduced airflow and lower temperature also contribute to the stabilization of moisture levels across the greenhouse [47, 67].

During daylight hours, the humidity ratio within the air of a plastic-covered greenhouse decreased from sunrise to midday, followed by a gradual increase until sunset (Figure 5). This variation is primarily driven by rising temperatures owing to increased solar radiation, which enhances the rate of evaporation. From midday to sunset, a reduction in solar radiation leads to lower temperatures, thereby reducing the rate of evaporation [11]. Conversely, the longitudinal variation in the air humidity ratio can be attributed to the dynamics of the air movement within the plastic-covered greenhouse. The entrance section of the greenhouse may be influenced more by external air exchange, which could result in a drier environment [28, 50, 68]. The absence of variation in the distribution of the air humidity ratio between the middle and rear sections of the plastic-covered greenhouse can be primarily attributed to the low rate of air circulation. Previous studies have suggested that ventilation openings at greenhouse entrances can lead to increased air exchange, resulting in lower humidity levels in these areas [69]. Furthermore,

improving the air circulation through side openings can substantially influence the uniformity of the environmental factor distribution within the greenhouse, including the air humidity ratio [70].

4.4. AIR HEAT CONTENT IN THE PLASTIC-COVERED GREENHOUSE

Greenhouse climate control systems typically depend on precise measurements of the heat content, including temperature and humidity. Accurate data are essential for the optimal functioning of heating, cooling, and ventilation systems, thereby maintaining a stable environment for plant growth and enhancing the overall operational efficiency [71].

The results demonstrate that the plastic-covered greenhouse acts as a heat trap, with the air inside generally having a higher heat content than that outside (Figure 6 and Table 4). Stability in the early morning, followed by rapid warming in the morning and longitudinal variation during the day, is typical of greenhouse environments where both external factors (solar radiation) and internal factors (ventilation and airflow) influence thermal dynamics [48, 68]. The longitudinal variation in air heat content within a plastic-covered greenhouse may be attributed to several factors, including variations in airflow dynamics, plant transpiration [51], or differences in the efficiency of heat absorption across different sections of the greenhouse [72].

The results presented in Figure 6 demonstrate that during nighttime hours, there was no significant difference in the air heat content between the interior and exterior of the plastic-covered greenhouse. Furthermore, no variation in the heat content was observed along the length of the greenhouse. However, a significant variation in the air heat content was noted during the daytime, both inside and along the length of the plastic-covered greenhouse. The variation in the air heat content within the plastic-covered greenhouse is primarily driven by fluctuations in the temperature and humidity dynamics [73].

During daytime hours, the greenhouse begins to accumulate heat as external temperatures increase and solar radiation intensifies [74]. The slight variation in the heat content along the length of the greenhouse during the early hours of the day can be attributed to the angle of solar radiation striking the greenhouse, resulting in varying rates of warming across different sections of the structure [42, 45]. The gradients in the heat content of air within a plastic-covered greenhouse can be attributed to variations in sunlight exposure [48], air movement rate and dynamics [28, 69], and the design of the greenhouse structure [45, 47].

5. CONCLUSION

This study evaluated the levels and longitudinal variations in key environmental factors (air temperature, relative humidity, humidity ratio, and heat content) that affect plant growth in a plastic-covered greenhouse. The findings revealed significant diurnal variations in greenhouse conditions. During the day, greenhouse temperatures exceed outdoor levels owing to the greenhouse effect, with the maximum temperature difference occurring at midday. At night, temperatures drop below outdoor levels because of radiative cooling. The relative humidity inside the greenhouse remained higher than that outside, fluctuating throughout the day. It peaks in the early morning hours, decreases at midday, and increases again toward the evening. These changes were influenced by temperature variations, plant transpiration, and ventilation. Nighttime humidity stabilized, reflecting reduced transpiration and air exchange. The humidity ratio followed a distinct daily pattern, increasing during the day and decreasing in the evening. The middle section of the greenhouse retained the highest moisture levels, whereas the entrance section was influenced more by external factors. The heat content is significantly higher inside the greenhouse during the day, particularly in the middle and end sections, owing to the reduced air circulation. At night, the heat content was equal across all sections, indicating thermal dissipation. Overall, plastic-covered greenhouses create distinct microclimatic conditions that differ from the external environment, with variations in the temperature, humidity, and heat distribution across the greenhouse. The effective management of these factors, including optimized ventilation and air circulation, is crucial for enhancing plant growth. This study recommends improving ventilation in plastic-covered greenhouses by optimizing natural ventilation systems, such as permeable shading nets that allow adequate airflow, or by employing mechanical ventilation systems powered by solar panels. These measures help regulate the airflow and temperature inside the greenhouse, ensuring better air circulation and reducing the heat buildup.

ACKNOWLEDGMENT

We sincerely thank Dr. Adel Al-Washli, Dean of the College of Agriculture, Food, and Environment, and Dr. Muhammad Rawah, Vice Dean for Environmental and Community Affairs, for their invaluable support in facilitating the implementation of the experiment in the Protected Agriculture Unit at Sana'a University.

Conflict of interest: The authors declare that they have no conflict of interest.

REFERENCES

- [1] F. Golzar, N. Heeren, S. Hellweg, and R. Roshandel, "A comparative study on the environmental impact of greenhouses: A probabilistic approach," *Sci. The Total. Environ.*, vol. 675, pp. 560–569, 2019.



- [2] H. Ahmed, A. Al-Faraj, and A. Abdel-Ghany, "Shading greenhouses to improve the microclimate, energy and water saving in hot regions: A review," *Sci. Hortic.*, vol. 201, pp. 36–45, 2016.
- [3] J. Tanny, "Microclimate and evapotranspiration of crops covered by agricultural screens: A review," *Biosyst. Eng.*, vol. 114, no. 1, pp. 26–43, 2013.
- [4] D. Katzin, E. Van Henten, and S. Van Mourik, "Process-based greenhouse climate models: Genealogy, current status, and future directions," *Agric. Syst.*, vol. 198, p. 103388, 2022.
- [5] M. Soussi, M. Chaibi, M. Buchholz, and Z. Saghruni, "Comprehensive review on climate control and cooling systems in greenhouses under hot and arid conditions," *Agronomy*, vol. 12, no. 3, p. 626, 2022.
- [6] S.-C. Vanegas-Ayala, J. Baron-Velandia, and D.-D. Leal-Lara, "A systematic review of greenhouse humidity prediction and control models using fuzzy inference systems," *Adv. Human-Computer Interact.*, vol. 2022, no. 1, 2022.
- [7] E. Ávalos-Sánchez et al., "Effect of greenhouse film cover on the development of fungal diseases on tomato (*solanum lycopersicum* L.) and pepper (*capsicum annuum* L.) in a mediterranean protected crop," *Agronomy*, vol. 13, no. 2, p. 526, 2023.
- [8] T. Li, J. Zhou, and J. Li, "Combined effects of temperature and humidity on the interaction between tomato and botrytis cinerea revealed by integration of histological characteristics and transcriptome sequencing," *Hortic. Res.*, vol. 10, no. 2, uhac257, 2023.
- [9] H. Ahmed, Y.-x. Tong, Q.-c. Yang, A. Al-Faraj, and A. Abdel-Ghany, "Spatial distribution of air temperature and relative humidity in the greenhouse as affected by external shading in arid climates," *J. Integr. Agric.*, vol. 18, no. 12, pp. 2869–2882, 2019.
- [10] G. Yu, S. Zhang, S. Li, M. Zhang, H. Benli, and Y. Wang, "Numerical investigation for effects of natural light and ventilation on 3d tomato body heat distribution in a venlo greenhouse," *Inf. Process. Agric.*, vol. 10, no. 4, pp. 535–546, 2023.
- [11] K. Xu, X. Guo, J. He, B. Yu, J. Tan, and Y. Guo, "A study on temperature spatial distribution of a greenhouse under solar load with considering crop transpiration and optical effects," *Energy Convers. Manag.*, vol. 254, p. 115277, 2022.
- [12] E. Brentarolli, S. Locatelli, C. Nicoletto, P. Sambo, D. Quaglia, and R. Muradore, "A spatio-temporal methodology for greenhouse microclimatic mapping," *PLoS One*, vol. 19, no. 9, e0310454, 2024.
- [13] A. M. Abdel-Ghany, I. M. Al-Helal, S. M. Alzahrani, A. A. Alsadon, I. M. Ali, and R. M. Elleithy, "Covering materials incorporating radiation-preventing techniques to meet greenhouse cooling challenges in arid regions: A review," *The Sci. World J.*, vol. 2012, no. 1, p. 906360, 2012.
- [14] H.-K. Kim, S.-Y. Lee, J.-K. Kwon, and Y.-H. Kim, "Evaluating the effect of cover materials on greenhouse microclimates and thermal performance," *Agronomy*, vol. 12, no. 1, p. 143, 2022.
- [15] R. Shamsiri, *Principles of Greenhouse Control Engineering*. Institute of Advanced Technology Universiti Putra Malaysia, 2007.
- [16] I. Dincer and M. A. Rosen, *Exergy analysis of heating, refrigerating and air conditioning: methods and applications*. Academic Press, 2015.
- [17] C. W. Callahan, A. M. Elansari, and D. L. Fenton, "Psychrometrics," in *Postharvest Technology of Perishable Horticultural Commodities*, Elsevier, 2019, pp. 271–310.
- [18] G. Sidebotham, *An Inductive Approach to Engineering Thermodynamics*. Springer Nature, 2022.
- [19] R. H. Howell, W. J. Coad, and H. J. Sauer Jr, *Principles of heating, ventilating, and air conditioning 7th Edition*. 2013.
- [20] J. Monteith and M. Unsworth, *Principles of environmental physics: plants, animals, and the atmosphere*. Academic Press, 2013.
- [21] K. Nemali, "History of controlled environment horticulture: Greenhouses," *HortScience*, vol. 57, no. 2, pp. 239–246, 2022.
- [22] ASHRAE, *2021 ASHRAE Handbook Fundamentals SI Edition*. 180 Technology Parkway, Peachtree Corners, GA 30092: ASHRAE, 2021.
- [23] M. Tahbaz, "Psychrometric chart as a basis for outdoor thermal analysis," *Int. J. Archit. Eng. & Urban Plan.*, vol. 21, no. 2, pp. 95–109, 2011.
- [24] Y. Hou et al., "Analysis of microclimate characteristics in solar greenhouses under natural ventilation," in *Building Simulation*, vol. 14, Springer, 2021, pp. 1811–1821.
- [25] L. Zheng et al., "Effects of diffuse light on microclimate of solar greenhouse, and photosynthesis and yield of greenhouse-grown tomatoes," *HortScience*, vol. 55, no. 10, pp. 1605–1613, 2020.
- [26] A. Reyes-Rosas, F. D. Molina-Aiz, D. L. Valera, A. López, and S. Khamkure, "Development of a single energy balance model for prediction of temperatures inside a naturally ventilated greenhouse with polypropylene soil mulch," *Comput. Electron. Agric.*, vol. 142, pp. 9–28, 2017.
- [27] A. M. Abdel-Ghany, "Solar energy conversions in the greenhouses," *Sustain. Cities Soc.*, vol. 1, no. 4, pp. 219–226, 2011.
- [28] H. Li et al., "Analysis of heat and humidity in single-slope greenhouses with natural ventilation," *Buildings*, vol. 13, no. 3, p. 606, 2023.
- [29] E. Driesen, W. V. den Ende, M. D. Proft, and W. Saeys, "Influence of environmental factors light, CO₂, temperature, and relative humidity on stomatal opening and development: A review," *Agronomy*, vol. 10, no. 12, p. 1975, 2020.
- [30] K. A. Mott and D. Peak, "Stomatal responses to humidity and temperature in darkness," *Plant, Cell & Environ.*, vol. 33, no. 7, pp. 1084–1090, 2010.
- [31] A. Chai et al., "Effect of temperature and humidity on dynamics and transmission of *Pseudomonas amygdali* pv. *lachrymans* aerosols," *Front. Plant Sci.*, vol. 14, p. 1087496, 2023.
- [32] J. H. Lee and K. Ramamurthi, *Fundamentals of thermodynamics*. CRC Press, 2022.
- [33] J.-P. Ansermet and S. D. Brechet, *Principles of thermodynamics*. Cambridge University Press, 2019.
- [34] I. Al-Helal, S. Waheeb, A. Ibrahim, M. Shady, and A. Abdel-Ghany, "Modified thermal model to predict the natural ventilation of greenhouses," *Energy Build.*, vol. 99, pp. 1–8, 2015.
- [35] T. Qian, J. Dieleman, A. Elings, A. De Gelder, and L. Marcelis, "Response of tomato crop growth and development to a vertical temperature gradient in a semi-closed greenhouse," *The J. Hortic. Sci. Biotechnol.*, vol. 90, no. 5, pp. 578–584, 2015.
- [36] F. Rodríguez, M. Berenguel, J. L. Guzmán, and A. Ramírez-Arias, *Modeling and control of greenhouse crop growth*. Springer, 2015.
- [37] A. B. Hückstädt, A. Suthaparan, L. Mortensen, and H. Gíslérød, "The effect of low night and high day temperatures on photosynthesis in tomato," *Am. J. Plant Sci.*, vol. 4, no. 12, pp. 2323–2331, 2013.

- [38] T. Lu et al., "Sub-high temperature and high light intensity induced irreversible inhibition on photosynthesis system of tomato plant (*Solanum lycopersicum* L.)," *Front. Plant Sci.*, vol. 8, p. 365, 2017.
- [39] H.-K. Kim, G.-C. Kang, J.-P. Moon, T.-S. Lee, and S.-S. Oh, "Estimation of thermal performance and heat loss in plastic greenhouses with and without thermal curtains," *Energies*, vol. 11, no. 3, p. 578, 2018.
- [40] A. Baille, J. López, S. Bonachela, M. González-Real, and J. Montero, "Night energy balance in a heated low-cost plastic greenhouse," *Agric. For. Meteorol.*, vol. 137, no. 1-2, pp. 107–118, 2006.
- [41] A. Al-Mahdouri, M. Baneshi, H. Gonome, J. Okajima, and S. Maruyama, "Evaluation of optical properties and thermal performances of different greenhouse covering materials," *Sol. Energy*, vol. 96, pp. 21–32, 2013.
- [42] G. Li, L. Tang, X. Zhang, J. Dong, and M. Xiao, "Factors affecting greenhouse microclimate and its regulating techniques: A review," in *IOP Conference Series: Earth and Environmental Science*, vol. 167, IOP Publishing, 2018, p. 012019.
- [43] H. A. Ahemd, A. A. Al-Faraj, and A. M. Abdel-Ghany, "Shading greenhouses to improve the microclimate, energy and water saving in hot regions: A review," *Sci. Hortic.*, vol. 201, pp. 36–45, 2016.
- [44] M. A. Fadel, B. A. B. Hammad, F. AlHosany, and O. Iwaimer, "Greenhouses covering materials: A comparative study," *Agric. Eng. Int. CIGR J.*, vol. 18, no. 1, pp. 48–57, 2016.
- [45] K. Mesmoudi, K. Meguallati, and P.-E. Bournet, "Effect of the greenhouse design on the thermal behavior and microclimate distribution in greenhouses installed under semi-arid climate," *Heat Transf. Asian Res.*, vol. 46, no. 8, 2017.
- [46] N. Choab, A. Allouhi, T. El Maakoul, T. Kousksou, S. Saadeddine, and A. Jamil, "Review on greenhouse microclimate and application: Design parameters, thermal modeling and simulation, climate controlling technologies," *Sol. Energy*, vol. 191, pp. 109–137, 2019.
- [47] S. Ghani et al., "Design challenges of agricultural greenhouses in hot and arid environments a review," *Eng. Agric. Environ. Food*, vol. 12, no. 1, pp. 48–70, 2019.
- [48] A. M. Abdel-Ghany, P. Picuno, I. Al-Helal, A. Alsadon, A. Ibrahim, and M. Shady, "Radiometric characterization, solar and thermal radiation in a greenhouse as affected by shading configuration in an arid climate," *Energies*, vol. 8, no. 12, pp. 13 928–13 937, 2015.
- [49] Q. Mao, H. Li, C. Ji, Y. Peng, and T. Li, "Experimental study of ambient temperature and humidity distribution in large multi-span greenhouse based on different crop heights and ventilation conditions," *Appl. Therm. Eng.*, vol. 248, p. 123 176, 2024.
- [50] M. C. Singh, K. K. Sharma, and V. Prasad, "Impact of ventilation rate and its associated characteristics on greenhouse microclimate and energy use," *Arab. J. Geosci.*, vol. 15, no. 3, p. 288, 2022.
- [51] J. Ge et al., "Combined effects of ventilation and irrigation on temperature, humidity, tomato yield, and quality in the greenhouse," *HortScience*, vol. 56, no. 9, pp. 1080–1088, 2021.
- [52] X. Lyu, Y. Xu, M. Wei, C. Wang, G. Zhang, and S. Wang, "Effects of vent opening, wind speed, and crop height on microenvironment in three-span arched greenhouse under natural ventilation," *Comput. Electron. Agric.*, vol. 201, p. 107 326, 2022.
- [53] S. Chia and M. Lim, "A critical review on the influence of humidity for plant growth forecasting," in *IOP Conference Series: Materials Science and Engineering*, vol. 1257, IOP Publishing, 2022, p. 012001.
- [54] E. Zhang, M. A. Jahid, J. Wang, N. Wang, and Q. Duan, "Investigating impacts of condensation on thermal performance in greenhouse glazing and operational energy use for sustainable agriculture," *Biosyst. Eng.*, vol. 236, pp. 287–301, 2023.
- [55] B. Rabbi, Z.-H. Chen, and S. Sethuvenkatraman, "Protected cropping in warm climates: A review of humidity control and cooling methods," *Energies*, vol. 12, no. 14, p. 2737, 2019.
- [56] R. R. Shamshiri, J. W. Jones, K. R. Thorp, D. Ahmad, H. C. Man, and S. Taheri, "Review of optimum temperature, humidity, and vapour pressure deficit for microclimate evaluation and control in greenhouse cultivation of tomato: A review," *Int. Agrophysics*, vol. 32, no. 2, pp. 287–302, 2018.
- [57] R. Price, *Climate change risks and opportunities in yemen*, No additional publication information provided, 2022.
- [58] X. Wei et al., "Distribution characteristics and prediction of temperature and relative humidity in a south china greenhouse," *Agronomy*, vol. 14, no. 7, p. 1580, 2024.
- [59] M. Suzuki et al., "Effects of relative humidity and nutrient supply on growth and nutrient uptake in greenhouse tomato production," *Sci. Hortic.*, vol. 187, pp. 44–49, 2015.
- [60] T. Rowlandson, M. Gleason, P. Sentelhas, T. Gillespie, C. Thomas, and B. Hornbuckle, "Reconsidering leaf wetness duration determination for plant disease management," *Plant Dis.*, vol. 99, no. 3, pp. 310–319, 2015.
- [61] A. G. Yusuf, F. A. Al-Yahya, A. A. Saleh, and A. M. Abdel-Ghany, "Optimizing greenhouse microclimate for plant pathology: Challenges and cooling solutions for pathogen control in arid regions," *Front. Plant Sci.*, vol. 16, p. 1 492 760, 2025.
- [62] S. Wu et al., "Research progress on efficient pollination technology of crops," *Agronomy*, vol. 12, no. 11, p. 2872, 2022.
- [63] K. Lalpekhlua, A. Tirkey, S. Saranya, and P. J. Babu, "Post-harvest management strategies for quality preservation in crops," *Int. J. Veg. Sci.*, vol. 30, no. 5, pp. 587–635, 2024.
- [64] M. H. Mahmood, M. Sultan, and T. Miyazaki, "Significance of temperature and humidity control for agricultural products storage: Overview of conventional and advanced options," *Int. J. Food Eng.*, vol. 15, no. 10, 2019.
- [65] Q. Mao and H. Li, "Simulation of ambient temperature and humidity distribution in eight-span greenhouse under different wind conditions and corn height," *Case Stud. Therm. Eng.*, vol. 61, p. 105 099, 2024.
- [66] E. L. Thipe, T. Workneh, A. Odindo, and M. Laing, "Greenhouse technology for agriculture under arid conditions," in *Sustainable Agriculture Reviews*, 2017, pp. 37–55.
- [67] S. Zeroual, S. Bougoul, and H. Benmoussa, "Effect of radiative heat transfer and boundary conditions on the airflow and temperature distribution inside a heated tunnel greenhouse," *J. Appl. Mech. Tech. Phys.*, vol. 59, pp. 1008–1014, 2018.
- [68] C.-R. Chu, T.-W. Lan, R.-K. Tasi, T.-R. Wu, and C.-K. Yang, "Wind-driven natural ventilation of greenhouses with vegetation," *Biosyst. Eng.*, vol. 164, pp. 221–234, 2017.
- [69] S. Benni, P. Tassinari, F. Bonora, A. Barbaresi, and D. Torreggiani, "Efficacy of greenhouse natural ventilation: Environmental monitoring and cfd simulations of a study case," *Energy Build.*, vol. 125, pp. 276–286, 2016.
- [70] K. He, D. Chen, L. Sun, Z. Huang, and Z. Liu, "Effects of vent configuration and span number on greenhouse microclimate under summer conditions in eastern china," *Int. J. Vent.*, vol. 13, no. 4, pp. 381–396, 2015.
- [71] R. Shamshiri and W. I. W. Ismail, "A review of greenhouse climate control and automation systems in tropical regions," *J. Agric. Sci. Appl.*, vol. 2, no. 3, pp. 176–183, 2013.



- [72] A. Mellalou, A. Mouaky, A. Bacaoui, and A. Outzourhit, "A comparative study of greenhouse shapes and orientations under the climatic conditions of marrakech, morocco," *Int. J. Environ. Sci. Technol.*, pp. 1–12, 2021.
- [73] C. Zhang, D. Zou, X. Huang, and Y. Wu, "Study on hot air heating characteristics of greenhouse in cold region," *Front. Energy Res.*, vol. 11, p. 1 038 182, 2023.
- [74] G. Gadhesaria, C. Desai, R. Bhatt, and B. Salah, "Thermal analysis and experimental validation of environmental condition inside greenhouse in tropical wet and dry climate," *Sustainability*, vol. 12, no. 19, p. 8171, 2020.